

Part. S0128S

Sideflexing



Part. S0128

Straight run



Part. S0128

Straight run



■ Roller side guides

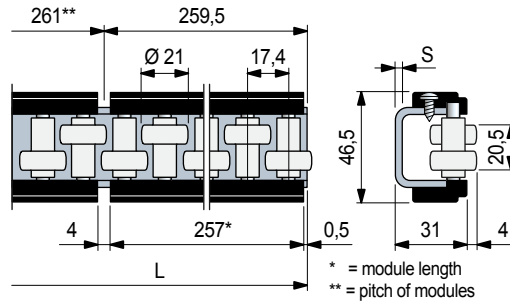

S mm	L mm	Metal profile and screws material	Code	Weight kg/m
------	------	-----------------------------------	------	-------------

Part. S0128S Sideflexing

2	3129	Zinc plated steel	6413600	2,06
		Austenitic stainless steel	6346600	

Part. S0128 Straight run

1041	2085	Zinc plated steel	64531	2,6
		Austenitic stainless steel	62640	
3	2085	Zinc plated steel	64541	
		Austenitic stainless steel	62670	
3129	3129	Zinc plated steel	64551	
		Austenitic stainless steel	63350	

- Material: rollers in acetal POM (white).
Side straps in polyamide PA (black).
Roller pins in ferritic stainless steel.

- Packaging: 2 strands.

- Accessories:



Guide - Rail Clamps.



Guide rail bending machine (manual) Part. S0218.

■ Roller side guides

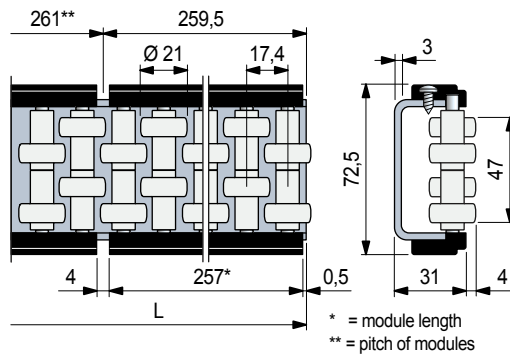

L mm	Metal profile and screws material	Code	Weight kg/m
------	-----------------------------------	------	-------------

1041	Zinc plated steel	64501	3,8
	Austenitic stainless steel	62650	
2085	Zinc plated steel	64511	
	Austenitic stainless steel	62680	
3129	Zinc plated steel	64521	
	Austenitic stainless steel	63340	

- Material: rollers in acetal POM (white).
Side straps in polyamide PA (black).
Roller pins in ferritic stainless steel.

- Packaging: 2 strands.

- Accessories:



Guide - Rail Clamps.

• Use of Part. S0128S - S0128
Rugged containers (ex. cases, cartons).

• Modular system

Guides are made of 257 mm long modules fixed on a metal "C" profile.

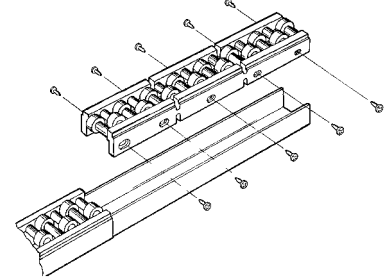

• Min. curvature radius (only for Part. S0128S)

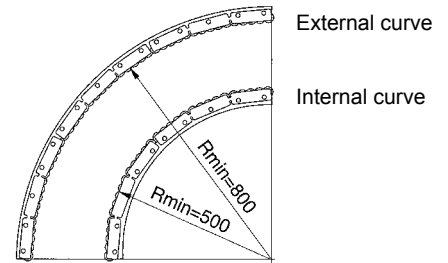

Curving procedure

- Disassemble the modules

- Curve the metal profile using the manual bending machine.

- Reassemble the modules

(the flexibility of the side straps make them easily adaptable to the curved profile).

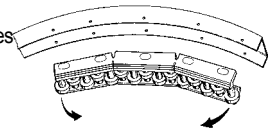

• Deflection of Part. S0128S - S0128

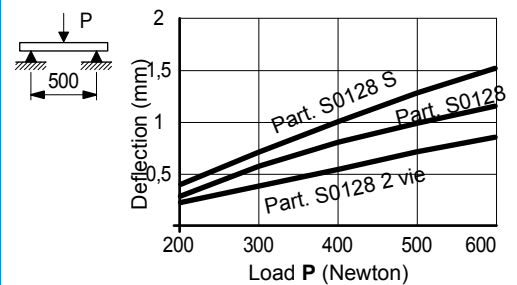

• Use of Part. S0128
Rugged containers (ex. cases, cartons).

• Modular system Part. S0128

Guides are made of 257 mm long modules fixed on a metal "C" profile.

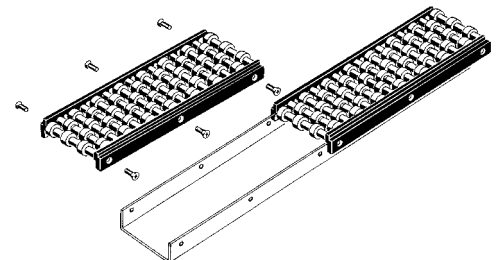

● Best Seller

● Standard

● On request: minimum quantity may apply. Consult our Customer Service for availability.

Item code for order = Part. + Code

- **Use of Part. S0128**
Rugged containers (ex. cases, cartons).

- **Modular system**
Guides are made of 257 mm long modules fixed on a metal "C" profile.

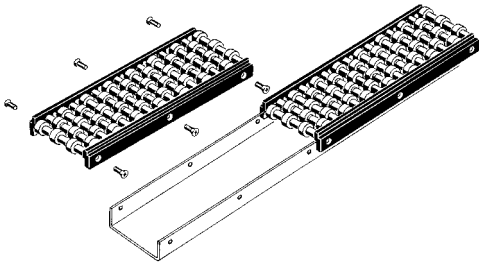

- **Deflection of Part. S0128**

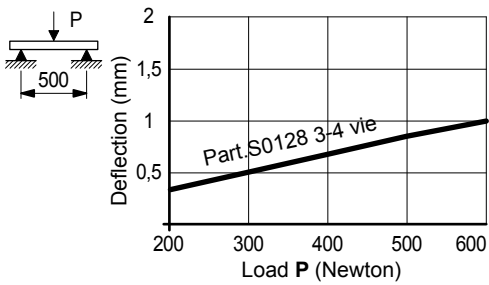

Roller side guides

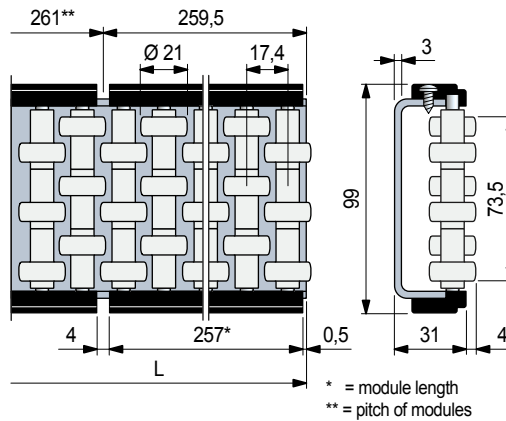

L mm	Metal profile and screws material	Code	Weight kg/m
1041	Zinc plated steel	64471	5,0
	Austenitic stainless steel	62660	
2085	Zinc plated steel	64481	5,0
	Austenitic stainless steel	62690	
3129	Zinc plated steel	64491	5,0
	Austenitic stainless steel	62890	

- Material: rollers in acetal POM (white). Side straps in polyamide PA (black). Roller pins in ferritic stainless steel.
- Packaging: 2 strands.
- Accessories:



Part. S0128

Straight run



Roller side guides

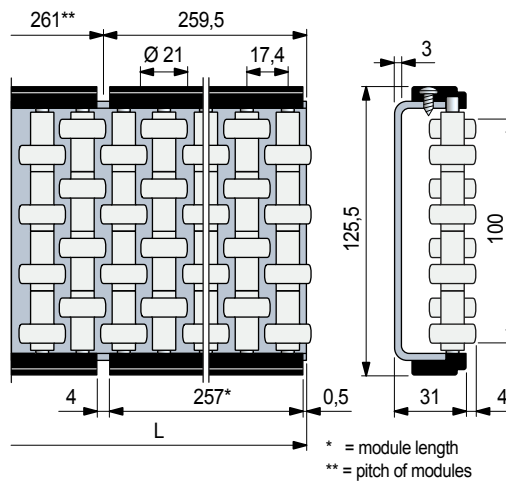

L mm	Metal profile and screws material	Code	Weight kg/m
3129	Austenitic stainless steel	609753	6,2

- Material: rollers in acetal POM (white). Side straps in polyamide PA (black). Roller pins in ferritic stainless steel.
- Packaging: 2 strands.
- Accessories:



Part. S0128

Straight run



- Best Seller
- Standard
- On request: minimum quantity may apply. Consult our Customer Service for availability.

Item code for order = Part. + Code